

REVISIONS		
LTR	DESCRIPTION	DATE
G	REVISED PER ECO-08-026728	10/27/2008

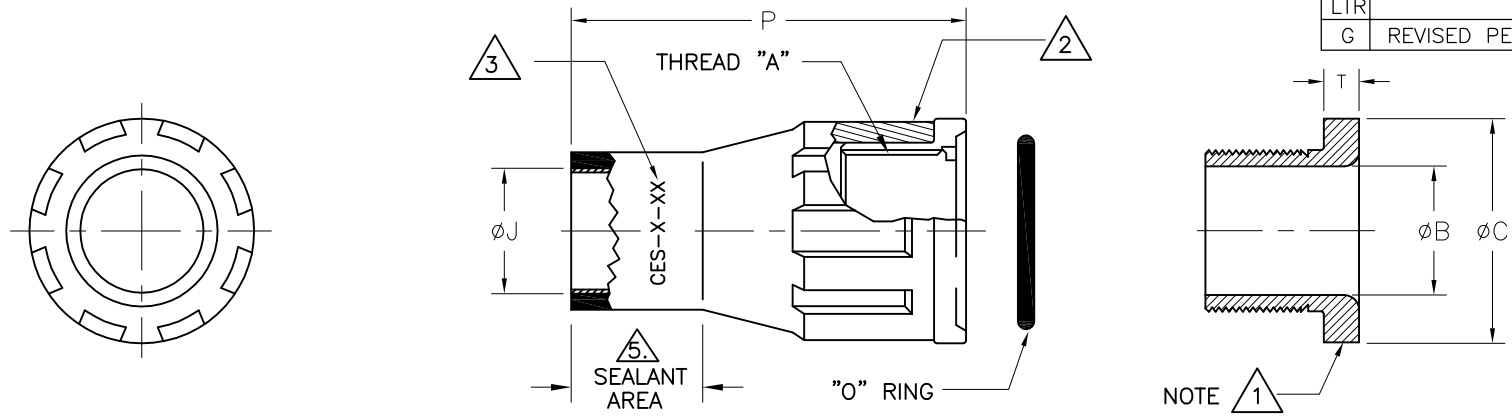

PART DESCRIPTION	"A" THREAD	ØB ±.02	ØC REF	ØJ		P REF REC	T REF	PANEL THK ⁴
				MIN EXP	MAX REC			
CES-1-XX	1-12 UNF	.75 [19,05]	1.40 [35,56]	.50 [12,7]	.16 [4,07]	2.45 [62,23]	.21 [5,34]	1/4 [6,35]
CES-2-XX	1-12 UNF	.75 [19,05]	1.40 [35,56]	.75 [19,05]	.25 [6,35]	2.45 [62,23]	.21 [5,34]	1/4 [6,35]
CES-3-XX	1 3/8-12 UNF	1.10 [27,94]	1.90 [48,26]	1.20 [30,48]	.50 [12,7]	3.55 [90,17]	.31 [7,88]	3/8 [9,65]
CES-4-XX	2-8 UN	1.56 [39,62]	2.70 [68,58]	1.60 [40,64]	.75 [19,05]	3.85 [97,79]	.31 [7,88]	1/2 [12,7]
CES-5-XX	3 3/8-8 UN	2.90 [73,66]	4.10 [104,14]	2.75 [70,48]	1.38 [35,06]	7.50 [190,50]	.31 [7,88]	3/4 [19,05]

NOTES:

- ¹ THE LAST TWO "X's" IN THE PART NUMBER DESIGNATE MATERIAL AS SHOWN BELOW:
 "AL": ALUMINUM 6061-T6 WITH FINISH OF HARD ANODIZE PER MIL-A-8625F, TYPE III, CLASS 2, DYED BLACK.
 "SS": STAINLESS STEEL TYPE 316, WITH FINISH OF PASSIVATE PER ASTM-A967.
 FOR STANDARD BLACK NYLON MATERIAL, OMIT THE LAST TWO "X's" IN THE PART NO.
- ² HEAT SHRINKABLE BOOT MATERIAL IN ACCORDANCE WITH -3 POLYOLEFIN
- ³ PART TO BE MARKED AS SHOWN, REPLACE "X's" WITH APPROPRIATE CHARACTERS (e.g. CES-3-AL).
- ⁴ THIS PART IS DESIGNED TO FIT THROUGH A PANEL OR BULKHEAD WITH A MAXIMUM WALL THICKNESS AS INDICATED IN TABLE.
- 5. FACTORY APPLIED HOT MELT ADHESIVE IS STANDARD.

If this document is printed it becomes uncontrolled. Check for the latest revision

CUSTOMER DRAWING

UNLESS OTHERWISE SPECIFIED DIMENSIONS ARE INCHES. METRIC DIMENSIONS ARE IN BRACKETS. DECIMAL TOLERANCES .XXX ± 0.005 [0.13 mm] .XX ± 0.01 [0.25 mm] .X ± 0.1 [0.50 mm] ANGLE TOLERANCE .X ± 1 DEG. TYCO ELECTRONICS RESERVES THE RIGHT TO AMEND THIS DRAWING AT ANY TIME. USERS SHOULD EVALUATE THE SUITABILITY OF THE PRODUCT FOR THEIR APPLICATION. © 2003-2008 Tyco Electronics Corporation. All rights reserved.	REVISED UNGUYEN	DATE 10/27/2008	 Raychem Molded Parts 305 Constitution Dr Menlo Park, CA 94025
	RPN N/A	TITLE CABLE ENTRY SEALS STANDARD	
THIRD ANGLE PROJECTION	SIZE B	CODE IDENT. NO. 06090	DWG. NO. CES-X-XX
DO NOT SCALE THIS DRAWING		SHEET 1 OF 1	